

# TX-3535RGBW4VSD1-0G4DB-01AH80

## PRODUCT SPECIFICATION

**Features:**

- ◆Excellent transiting heat from LED chip operating under 500mA
- ◆High luminous output
- ◆No UV

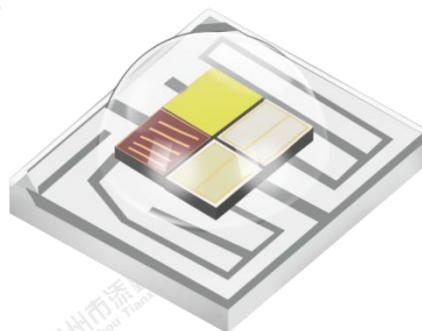

**Moisture Proof Grade:**

- ◆LEVEL1

**Emitting Color:**

- ◆Red (R)
- ◆Green (G)
- ◆Blue (B)
- ◆White (W)

**Applications:**

- ◆Portable flashlight
- ◆Garden lighting
- ◆General lighting

Part No.	TX-3535RGBW4VSD1-0G4DB-01AH80	Spec No.	WKF-ED0149	Page	1 of 11
----------	-------------------------------	----------	------------	------	---------

**Package Dimensions:**

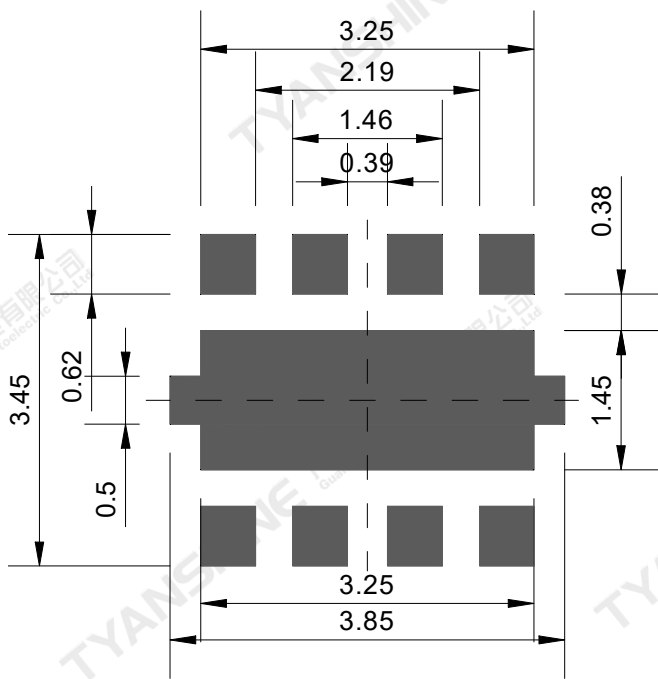
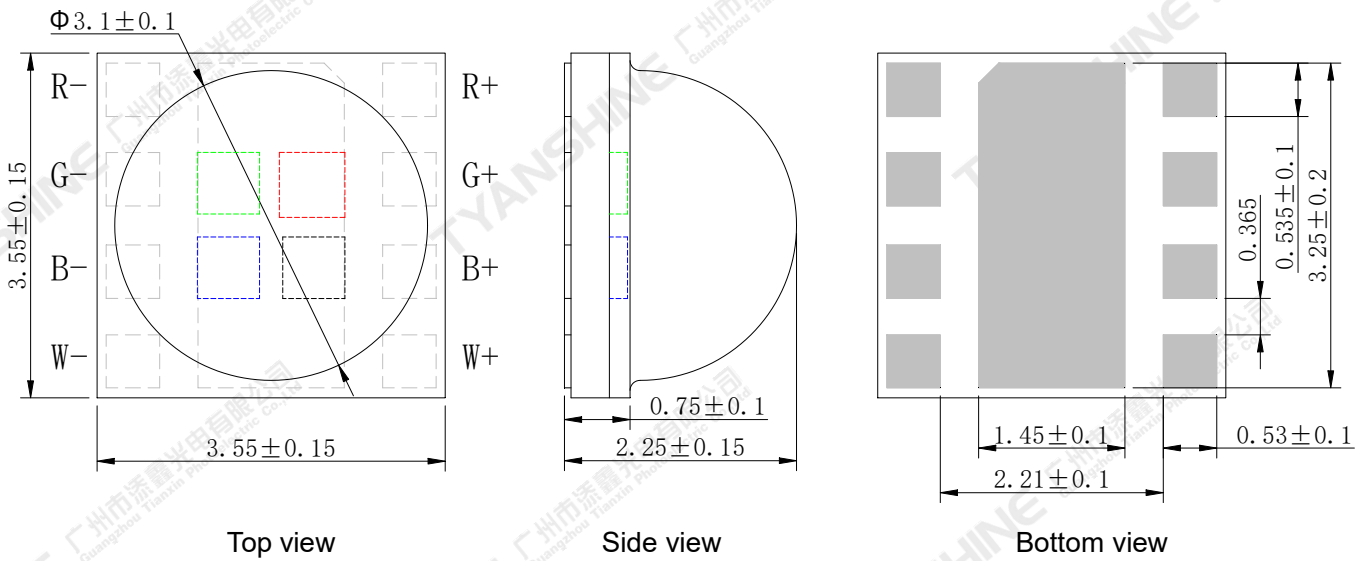

Recommended solder pad

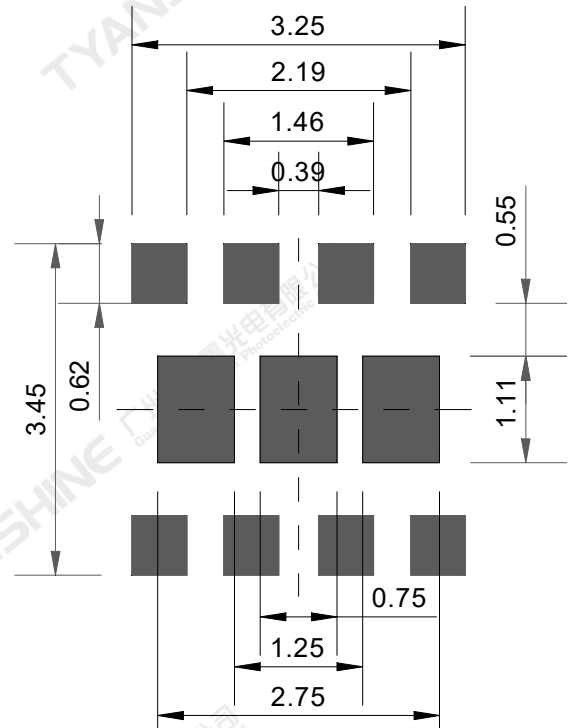

Recommended stencil pattern

**Notes:**

1. All dimensions are in millimeters .
2. Tolerances unless otherwise mentioned are  $\pm 0.15$ mm .

**Absolute Maximum Ratings (Tc=25°C)**

Parameter	Symbol	Max Ratings	Unit	
Forward Current	IF	500	mA	
Peak Forward Current (Condition 1)	IFP	600		
Reverse Voltage	VR	Not designed for reverse operation	V	
Power Dissipation	PD	R	1150	mW
		G	1600	
		B	1600	
		W	1600	
Junction Temperature	Tj	R	125	°C
		G	150	
		B	150	
		W	150	
Electrostatic Discharge Threshold (ESD)	ESD	2000	V	
Storage Temperature	Tstg	-40~70	°C	
Operation Temperature	Topr	-30~85		
Ceramic side temperature(Notes 4)	Tcs	85		

Condition 1.Pulse width ≤0.1 msec, duty ≤1/10.

**Notes:**

- Specifications are subject to change without notice.
- The data on this specification is for reference only and the actual data is in accordance with the acknowledgment.
- Precautions for ESD:  
STATIC SHIELD Electricity and surge damages the LED. It is recommended to use a wrist band or anti-electrostatic glove when handling the LED. All devices, equipment and machinery must be properly grounded.
- Temperature on the side of the ceramic substrate near the heat sink.

Part No.	TX-3535RGBW4VSD1-0G4DB-01AH80	Spec No.	WKF-ED0149	Page	3 of 11
----------	-------------------------------	----------	------------	------	---------

**Electrical Optical Characteristics (Tc=25°C, IF=350mA)**

Parameter	Symbol	Emitting Color	Min.	Typ.	Max.	Units
Luminous Flux	$\Phi_v$	R	58	65	72	lm
		G	90	105	120	
		B	27	31	36	
		W	85	100	120	
Dominant Wavelength	$\lambda_d$	R	620	622.5	625	nm
		G	523	527	532	
		B	465	468	472	
Correlated Colour Temperature	CCT	W	3780	4120	4500	K
			4800	5150	5500	
			5700	6300	7000	
Color Rendering Index	Ra	W	80	83	—	—
Peak-emission Wavelength	$\lambda_p$	R	627	629.5	632	nm
		G	519	524	527	
		B	462	465	469	
Spectral Line Half-Width	$\Delta\lambda$	R	15	20	25	nm
		G	30	35	40	
		B	20	25	30	
		W	20	25	30	
Forward Voltage	$V_f$	R	2.0	2.15	2.3	V
		G	2.9	3.05	3.2	
		B	2.9	3.05	3.2	
		W	2.9	3.05	3.2	
Reverse Current	$I_R$	$V_R=5V$	—	—	5	$\mu A$
Viewing Angle at 50% IV	$2\theta_{1/2}$	—	—	120	—	Deg
Thermal Resistance Junction to Case	$R\theta_{J-C}$	R	—	8.5	—	K/W
		G	—		—	
		B	—		—	
		W	—		—	
Temperature Coefficient of Voltage	$V\Delta F/T$	R	—	-2.0	—	mV/°C
		G	—	-5.8	—	
		B	—	-1.6	—	
		W	—	-1.6	—	

**White Color coordinate filing (IF=350mA)**

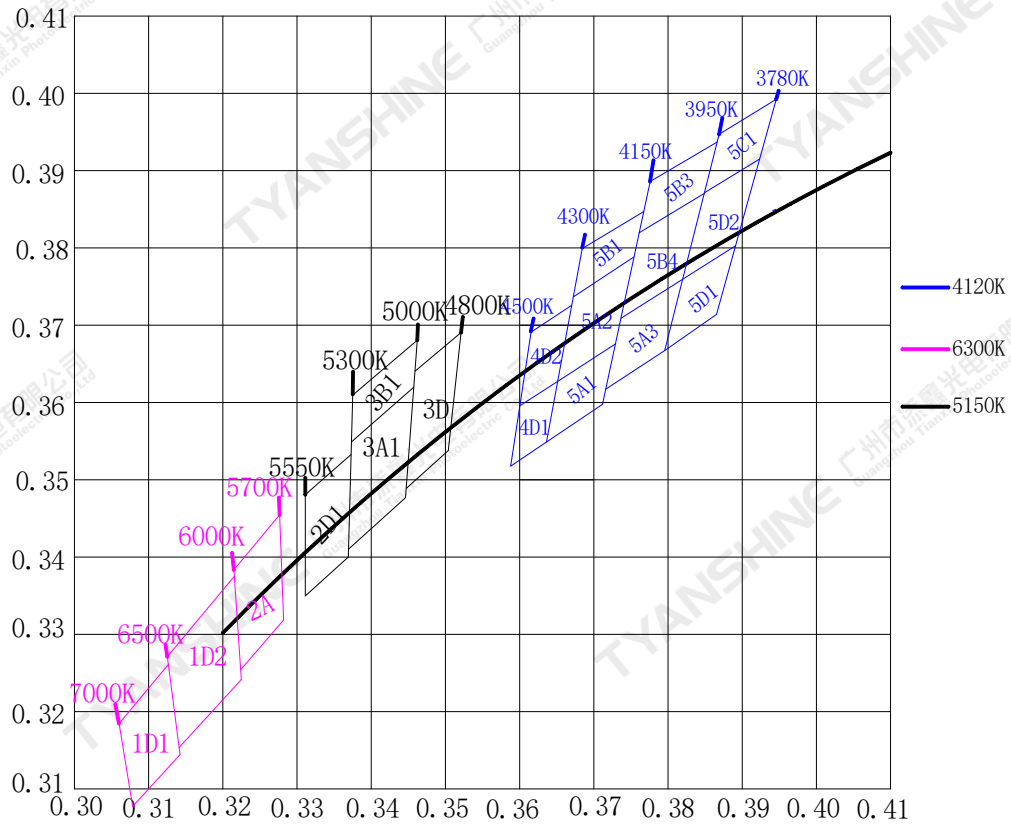

Region	CCT Range		X1	Y1	X2	Y2	X3	Y3	X4	Y4
	Min	Max								
5D1	3780K	3950K	0.3796	0.3667	0.3820	0.3759	0.3891	0.3803	0.3865	0.3714
5D2			0.3820	0.3759	0.3849	0.3871	0.3924	0.3915	0.3891	0.3803
5C1			0.3849	0.3871	0.3869	0.3947	0.3946	0.3992	0.3924	0.3915
5A3	3950K	4150K	0.3716	0.3617	0.3737	0.3709	0.3820	0.3759	0.3796	0.3667
5B4			0.3737	0.3709	0.3761	0.3820	0.3849	0.3870	0.3820	0.3759
5B3			0.3761	0.3820	0.3776	0.3886	0.3866	0.3937	0.3849	0.3870
5A1	4150K	4300K	0.3636	0.3549	0.3651	0.3627	0.3729	0.3676	0.3712	0.3598
5A2			0.3651	0.3627	0.3672	0.3737	0.3754	0.3788	0.3729	0.3676
5B1			0.3672	0.3737	0.3684	0.3799	0.3767	0.3847	0.3754	0.3788
4D1	4300K	4500K	0.3588	0.3518	0.3600	0.3596	0.3651	0.3627	0.3636	0.3549
4D2			0.3600	0.3596	0.3616	0.3691	0.3670	0.3726	0.3651	0.3627
2A	5700K	6000K	0.3282	0.3319	0.3224	0.3254	0.3215	0.3383	0.3277	0.3455
1D2	6000K	6500K	0.3225	0.3242	0.3141	0.3154	0.3125	0.3271	0.3216	0.3375
1D1	6500K	7000K	0.3142	0.3144	0.3079	0.3077	0.3060	0.3185	0.3126	0.3261
3D	4800K	5000K	0.3448	0.3489	0.3459	0.3641	0.3521	0.3690	0.3504	0.3538
3B1	5000K	5300K	0.3373	0.3549	0.3375	0.3610	0.3462	0.3681	0.3457	0.3620
3A1	5000K	5300K	0.3369	0.3410	0.3373	0.3549	0.3457	0.3620	0.3446	0.3477
2D1	5300K	5500K	0.3311	0.3350	0.3311	0.3481	0.3373	0.3533	0.3369	0.3400

**Notes:**

- 1.Luminous intensity is measured with a light sensor and filter combination that approximates the CIE eye-response curve.
2. $\theta_{1/2}$  is the off-axis angle at which the luminous intensity is half the axial luminous intensity.
- 3.Luminous flux measurement tolerance: $\pm 10\%$ .
- 4.Forward voltage measurement tolerance: $\pm 0.3V$ .
- 5.Ra measurement tolerance: $\pm 2$ .

## Typical Electrical/Optical Characteristics Curves

(25°C Ambient Temperature Unless Otherwise Noted)

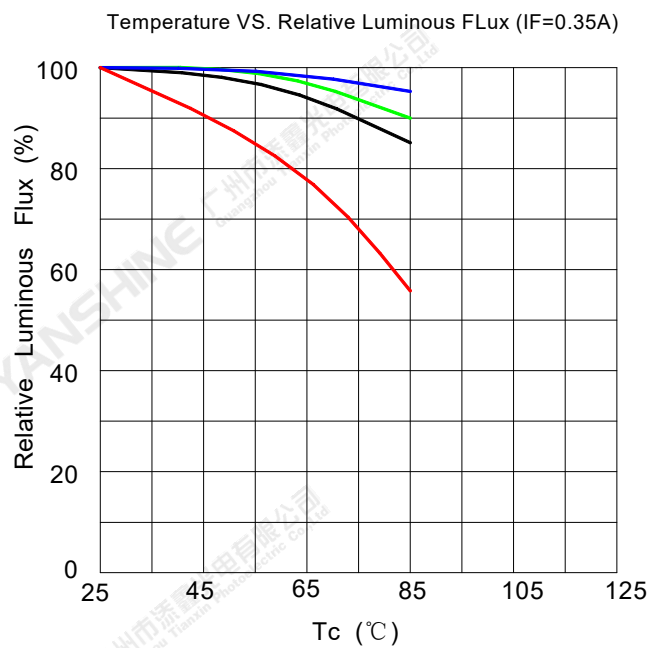
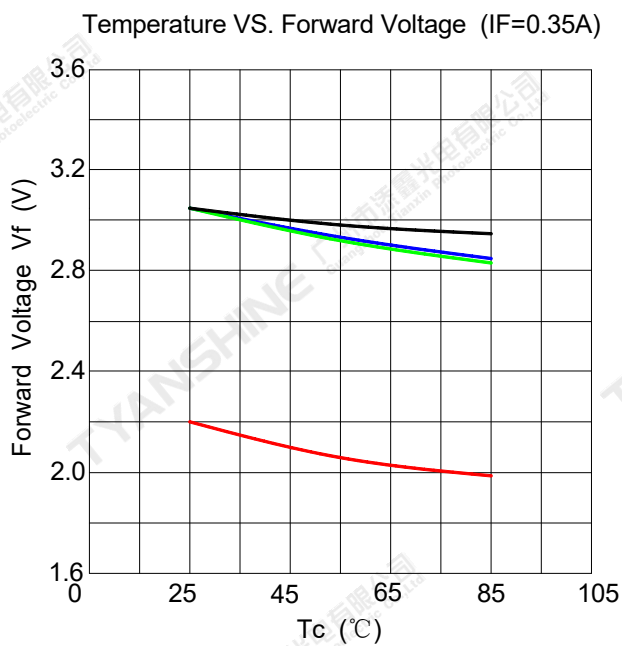
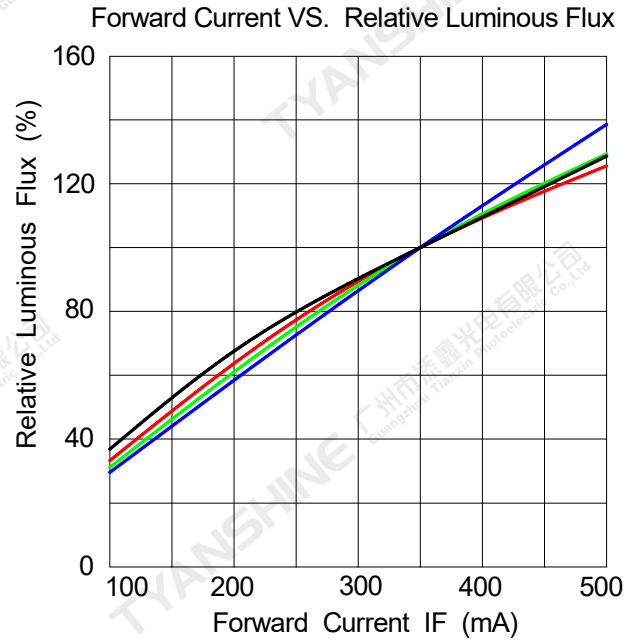
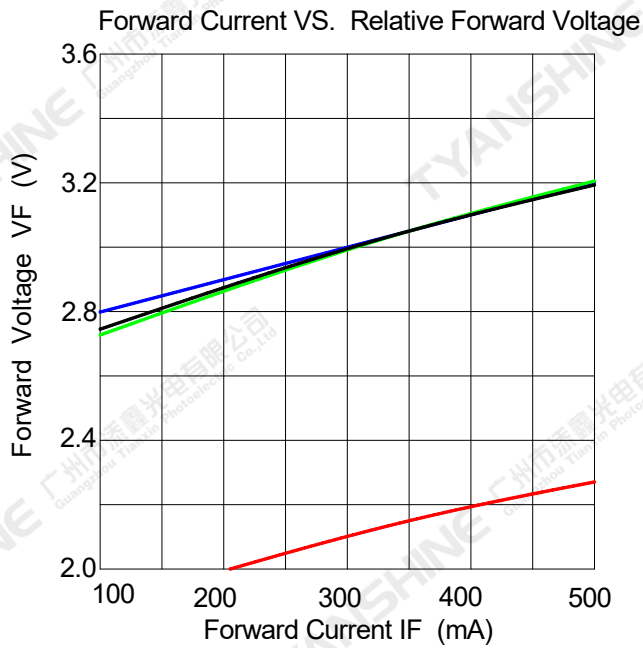

**Notes:** — Red (R) ; — Green (G) ; — Blue (B) ; — White (W) ;

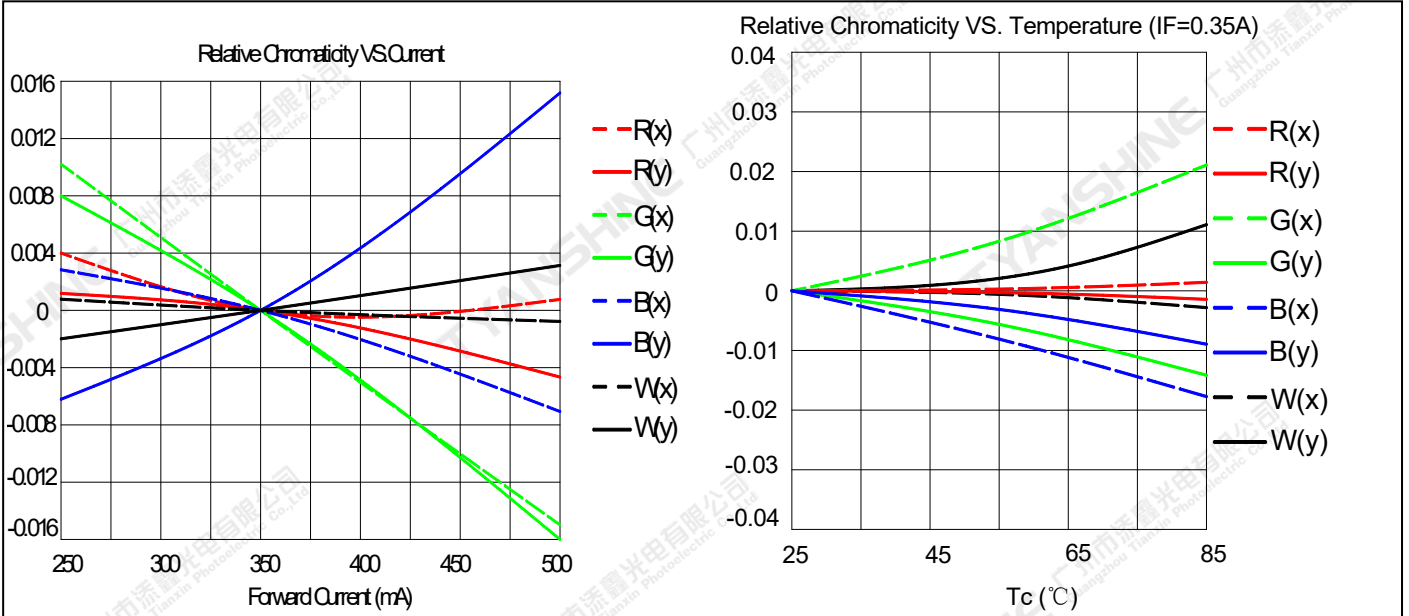

**Notes:** Red (R) ; Green (G) ; Blue (B) ; White (W) ;

**Relative Spectral Distribution**

Spectral Radiance: Red Peak@630nm Green Peak@525nm Blue Peak@465nm

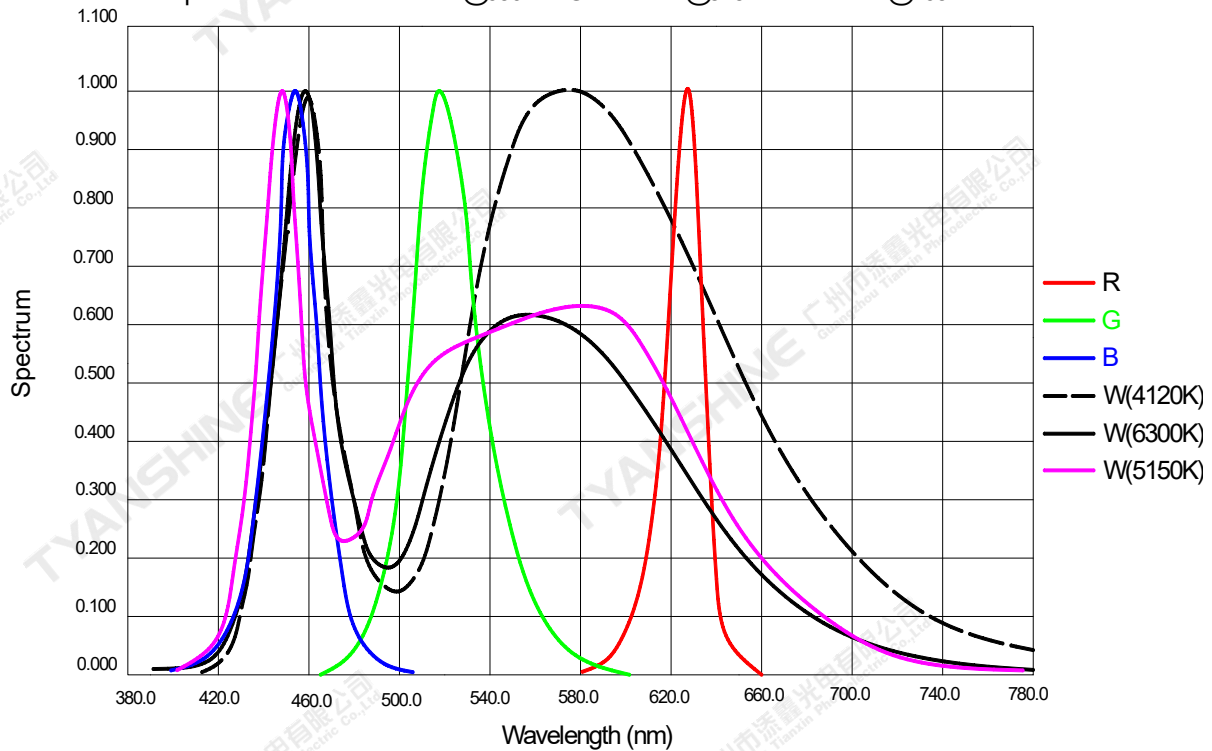

**Notes:**

1.  $2\theta_{1/2}$  is the off axis angle from lamp centerline where the luminous intensity is 1/2 of the peak value.
2. View angle tolerance is  $\pm 5^\circ$ .

## Usage Precautions

### Storage Environment Condition

Temperature: 5°C ~ 30°C (41°F ~ 86°F)

Humidity: 60% RH Max.

### Soldering Condition

Use the conditions shown to the under figure.

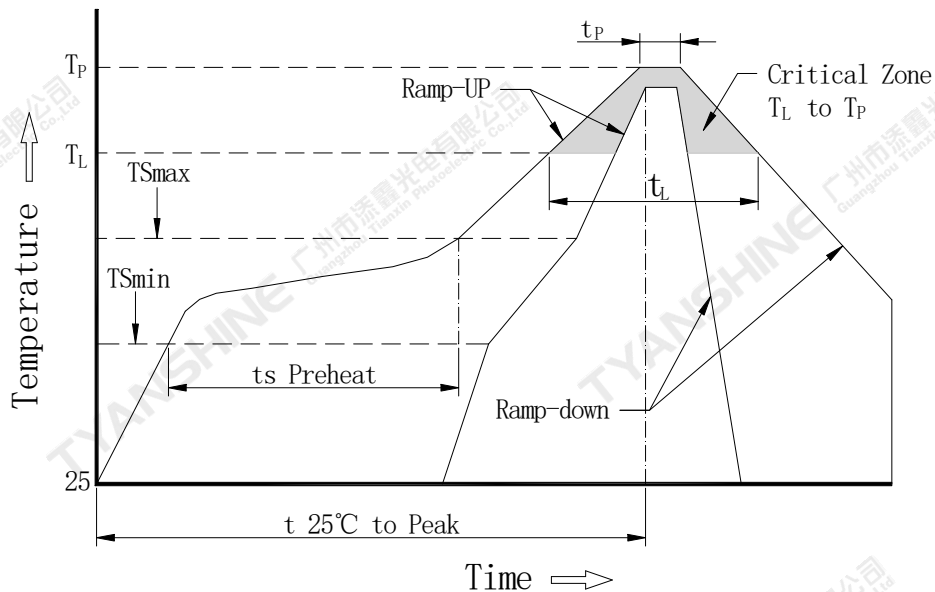

Profile Feature	Pb-Free Solderr(SnBi35Ag0.3)
Average Ramp-Up Rate (Tsmax to Tp)	3°C/second max.
Preheat: Temperature Min (Tsmin)	130°C
Preheat: Temperature Max (Tsmax)	190°C
Preheat: Time (Tsmin to Tsmax)	120-180 seconds
Time Maintained Above: Temperature (Tl)	230°C
Time Maintained Above: Time (Tl)	60-150 seconds
Peak/Classification Temperature (Tp)	255°C
Time Within 5°C of Actual Peak Temperature (Tp)	10-35seconds
Ramp-Down Rate	5°C/second max.
Time 25°C to Peak Temperature	7 minutes max.

### Note:

All temperatures refer to topside of the package, measured on the package body surface.

**Dimensions For Cannulation And Packaging**

**Quantity: 1000PCS**

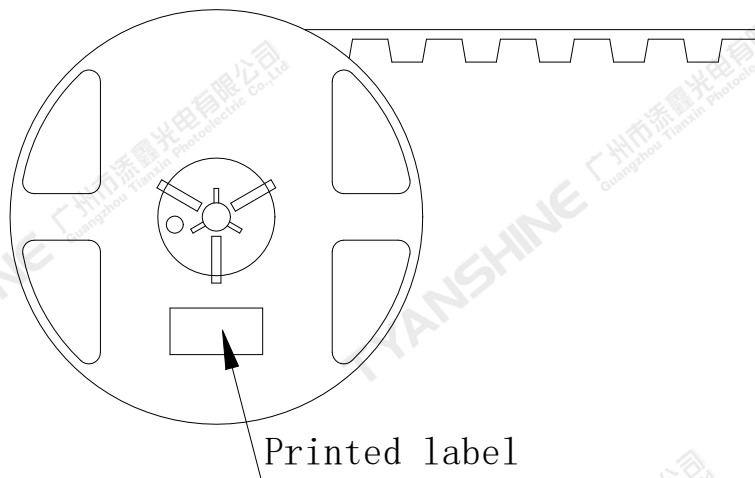
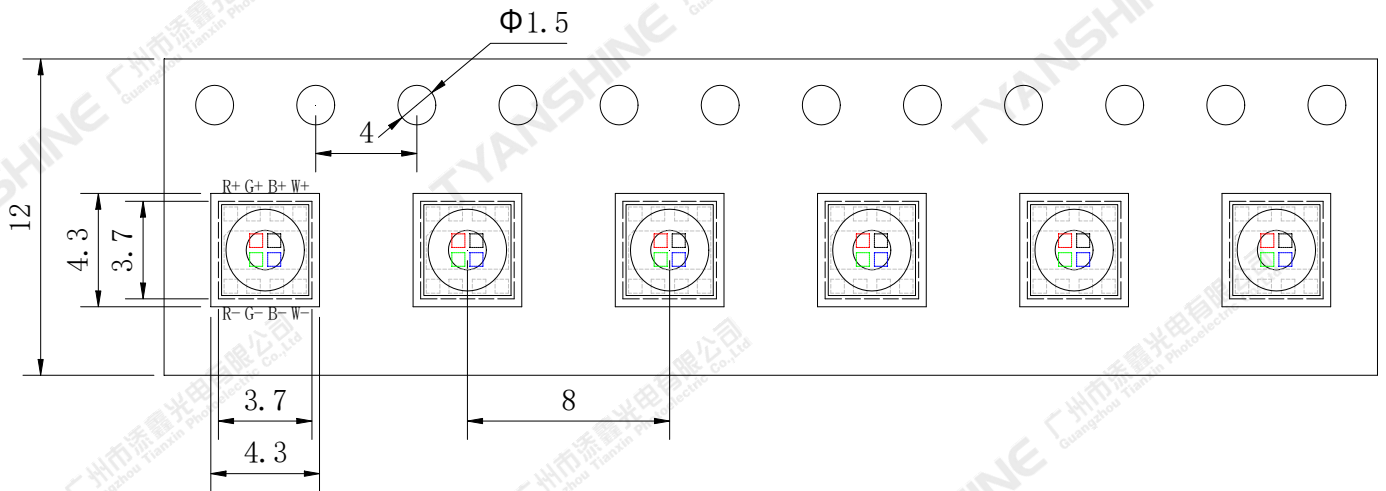

**Notes:**

1. All dimensions are in millimeters.
2. Tolerances are  $\pm 2.0$  mm unless otherwise noted.
3. The products are packaged together with silica gel, Transport, not to the weight of welding LED light-emitting area, As a result of the weight of LED light-emitting zone in the quality of, Irresponsible of the Company.

Part No.	TX-3535RGBW4VSD1-0G4DB-01AH80	Spec No.	WKF-ED0149	Page	10 of 11
----------	-------------------------------	----------	------------	------	----------

