

TX-1212RGBW200FC120-NUVENG-01A

PRODUCT SPECIFICATION

Features:

- ◆Excellent transiting heat from LED chip operating under 1.0A.
- ◆High luminous output.
- ◆Encapsulated materials are environmentally certified and meet environmental requirements.

Chip Material:

- ◆Red: AlInGaP
- ◆Green: GaInN
- ◆Blue: GaN
- ◆White:GaN

Emitting Color:

- ◆Red(R1/R2)
- ◆Green(G1/G2)
- ◆Blue(B1/B2)
- ◆White(W1/W2/W3)

Applications:

- ◆Stage lighting
- ◆Landscape Lighting
- ◆Entertainment lighting

Part No.	TX-1212RGBW200FC120-NUVENG-01A	Spec No.	PE-B20260601-1	Page	1 of 10
----------	--------------------------------	----------	----------------	------	---------

Package Dimensions:

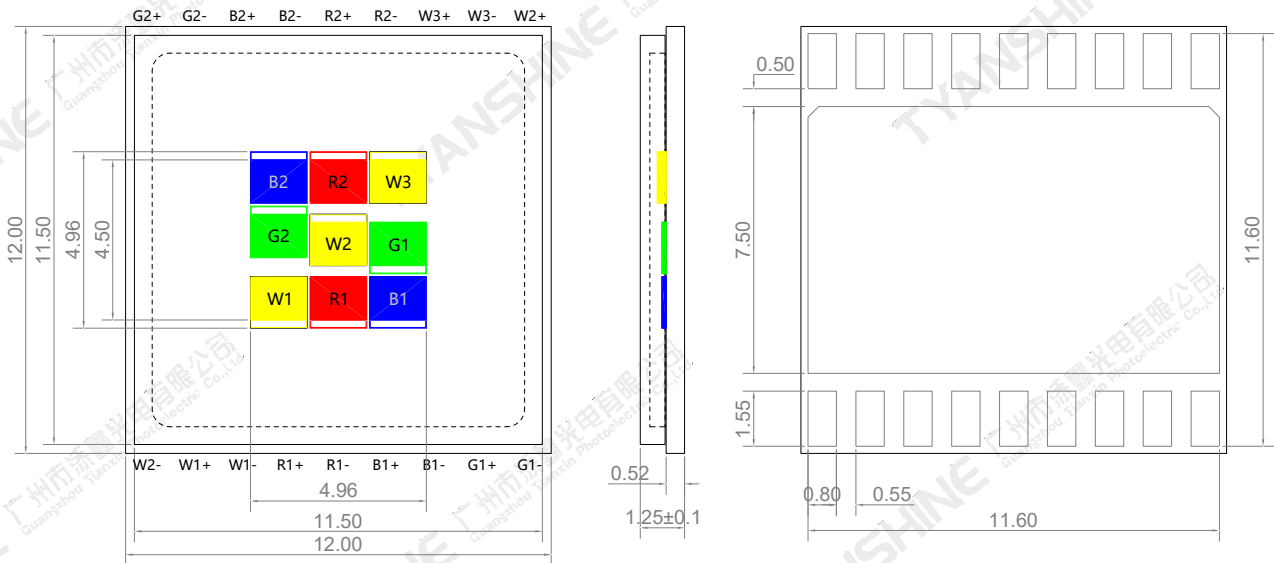

Notes:

- 1.All dimensions are in millimeters .
- 2.Tolerances unless otherwise mentioned are ±0.1mm .

Part No.	TX-1212RGBW200FC120-NUVENG-01A	Spec No.	PE-B20260601-1	Page	2 of 10
----------	--------------------------------	----------	----------------	------	---------

Absolute Maximum Ratings (Tc=25°C)

Parameter	Symbol	Max Ratings	Unit	
Forward Current	IF	R1	5.0	A
		R2	5.0	
		G1	7.0	
		G2	7.0	
		B1	7.0	
		B2	7.0	
		W1	5.0	
		W2	5.0	
		W3	5.0	
Reverse Voltage	V _R	—	Not designed for reverse operation	V
Power Dissipation	P _D	R1	15	W
		R2	15	
		G1	25	
		G2	25	
		B1	26	
		B2	26	
		W1	19	
		W2	19	
		W3	19	
Junction Temperature	T _j	R1/R2	115	°C
		G1/G2	150	
		B1/B2	150	
		W1/W2/W3	150	
Electrostatic Discharge Threshold (ESD)	ESD	2000	V	
Storage Temperature(Only for LED, not including packaging)	T _{stg}	-40~+85	°C	
Operation Temperature	T _{opr}	-40~+85		

Notes:

- Specifications are subject to change without notice.
- The data on this specification is for reference only and the actual data is in accordance with the acknowledgment.
- Precautions for ESD:
STATIC SHIELD Electricity and surge damages the LED. It is recommended to use a wrist band or anti-electrostatic glove when handling the LED. All devices, equipment and machinery must be properly grounded.

Part No.	TX-1212RGBW200FC120-NUVENG-01A	Spec No.	PE-B20260601-1	Page	3 of 10
----------	--------------------------------	----------	----------------	------	---------

Electrical Optical Characteristics (If=1.0A;Tc=25°C)

Parameter	Symbol	Emitting Color	Min.	Typ.	Max.	Units
Luminous Flux	ϕ_v	R1	110	135	155	lm
		R2	110	135	155	
		G1	320	380	420	
		G2	320	380	420	
		B1	47	55	65	
		B2	47	55	65	
		W1	340	400	450	
		W2	340	400	450	
Dominant Wavelength	λ_d	R1/R2	618	623	628	nm
		G1/G2	527	532	537	
		B1/B2	450	455	460	
Correlated Colour Temperature	CCT	W1/W2/W3	5700	—	6350	K
Peak-emission Wavelength	λ_p	R1/R2	625	630	635	nm
		G1/G2	518	523	528	
		B1/B2	445	450	455	
Spectral Line Half-Width	$\Delta\lambda$	R1/R2	11	16	21	nm
		G1/G2	23	28	33	
		B1/B2	12	17	22	
		W1/W2/W3	12	17	22	
Forward Voltage	V_f	R1/R2	2.0	2.4	2.8	V
		G1/G2	2.6	3.0	3.4	
		B1/B2	2.8	3.2	3.6	
		W1/W2/W3	2.8	3.2	3.6	
Reverse Current	I_R	—	—	—	—	μA
Viewing Angle at 50% IV	$2\theta_{1/2}$	—	—	120	—	Deg
Temperature Coefficient of Voltage	$V\Delta F/T$	R1/R2	—	-4.07	—	mV/°C
		G1/G2	—	-8.95	—	
		B1/B2	—	-5.99	—	
		W1/W2/W3	—	-4.04	—	

Notes:

- 1.Luminous intensity is measured with a light sensor and filter combination that approximates the CIE eye-response curve.
2. $\theta_{1/2}$ is the off-axis angle at which the luminous intensity is half the axial luminous intensity.
- 3.The dominant wavelength (λ_d) is derived from the CIE chromaticity diagram and represents the single wavelength which defines the color of the device.
- 4.Luminous flux measurement tolerance: $\pm 15\%$.
- 5.Forward voltage measurement tolerance: $\pm 0.15V$.

White light Color coordinate filing (If=1.0A,Tc=25°C)

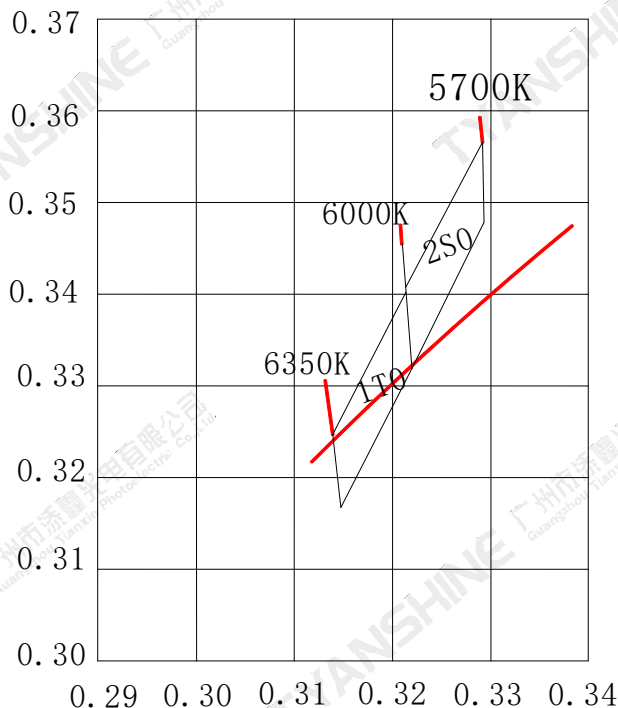

Region	CCT Range		X1	Y1	X2	Y2	X3	Y3	X4	Y4
	Min	Max								
2S0	5700K	6000K	0.3293	0.3478	0.3291	0.3566	0.3213	0.3408	0.3220	0.3319
1T0	6000K	6350K	0.3220	0.3319	0.3214	0.3403	0.3139	0.3247	0.3147	0.3167

Typical Electrical/Optical Characteristics Curves

(25°C Ambient Temperature Unless Otherwise Noted)

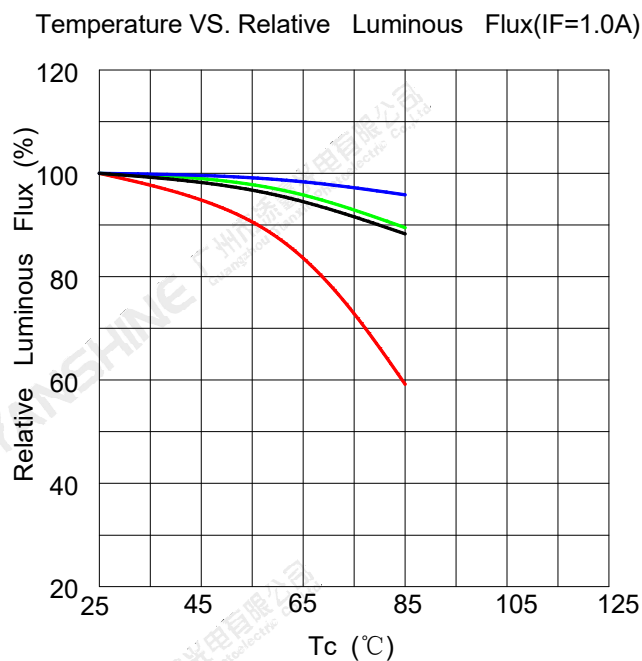
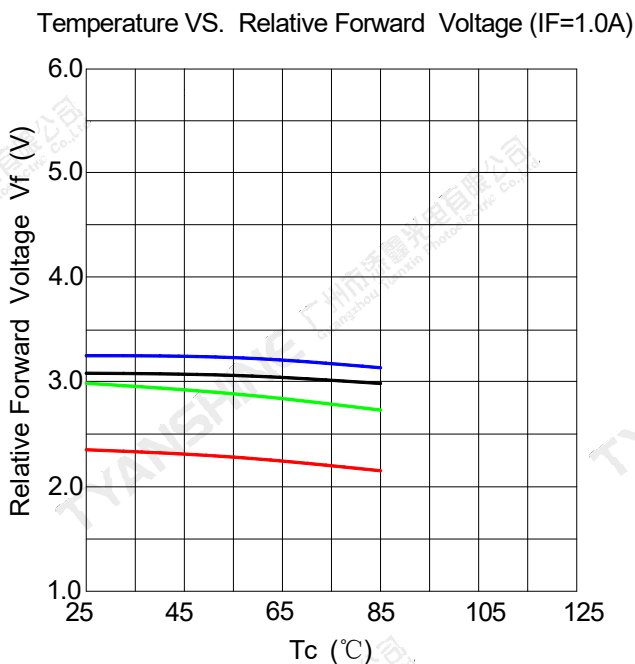
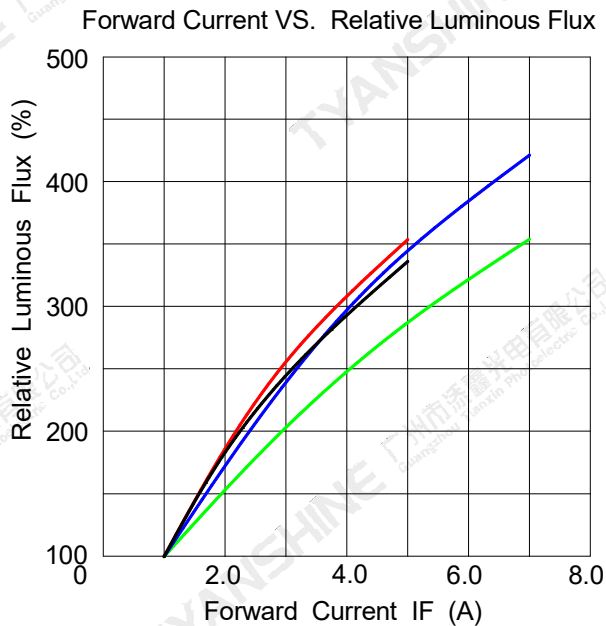
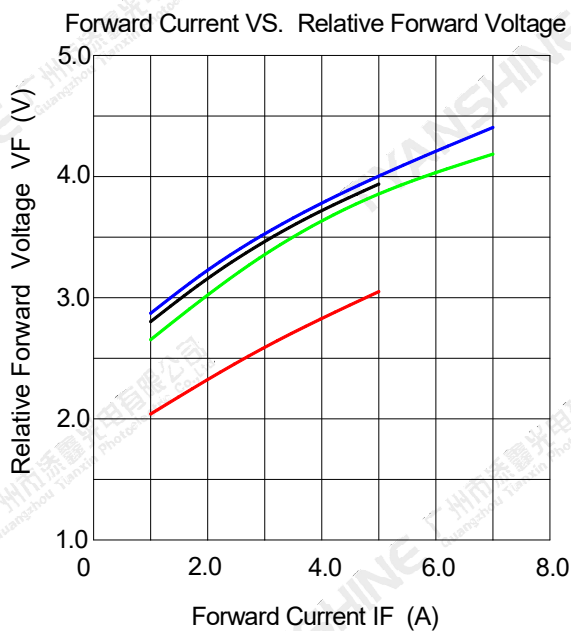

Notes: — Red; — Green; — Blue; — White;

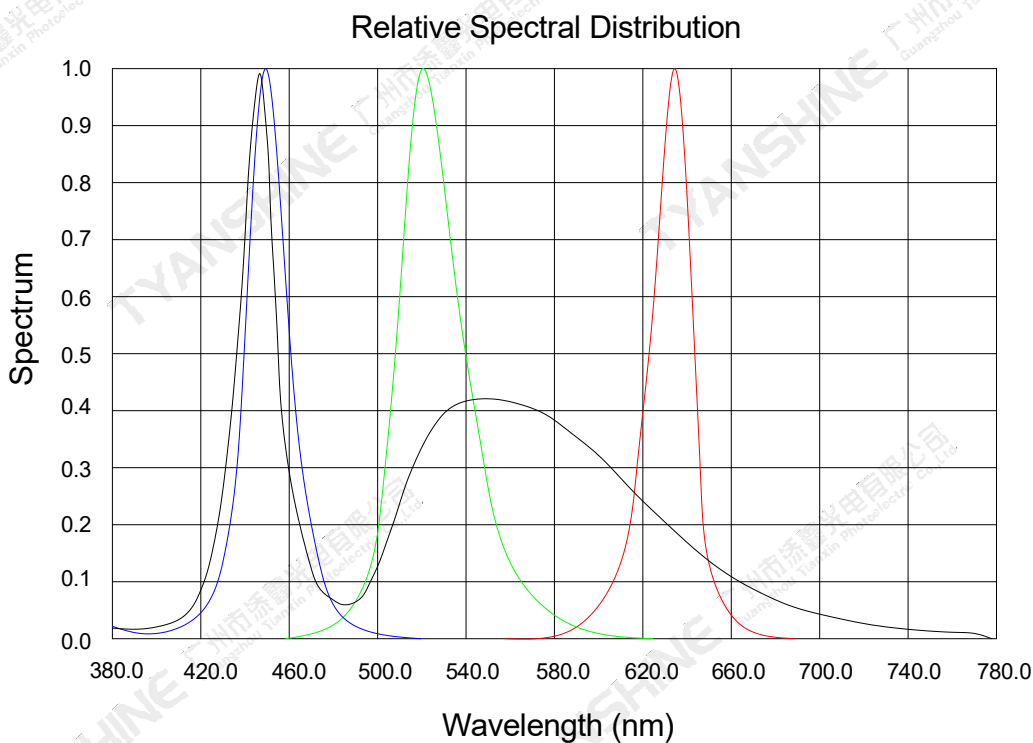
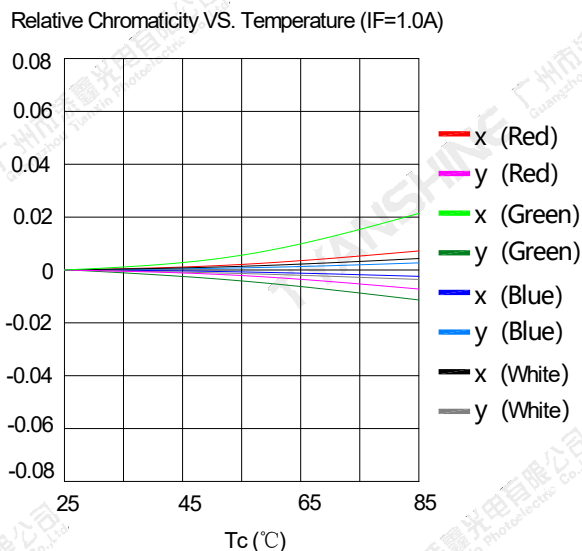
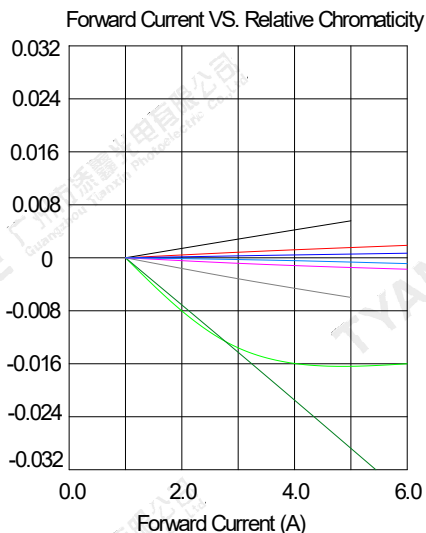

Notes: — Red; — Green; — Blue; — White;

Notes:

1. 2θ 1/2 is the off axis angle from lamp centerline where the luminous intensity is 1/2 of the peak value.
2. View angle tolerance is $\pm 5^\circ$.

Part No.	TX-1212RGBW200FC120-NUVENG-01A	Spec No.	PE-B20260601-1	Page	7 of 10
----------	--------------------------------	----------	----------------	------	---------

Usage Precautions

Storage Environment Condition

Temperature: 5°C ~ 30°C (41°F ~ 86°F)

Humidity: 60% RH Max.

Soldering Condition

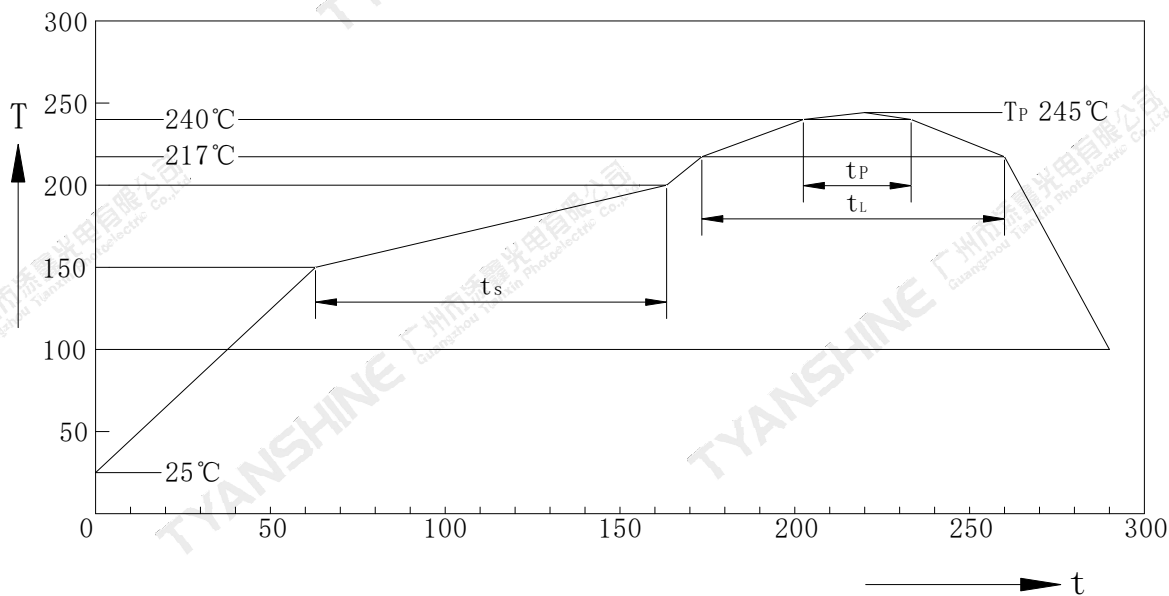

Profil-Charakteristik Profile Feature	Symbol	Pb-Free(SnAgCu)Assembly			Einheit Unit
		Minimum	Recommendation	Maximum	
Ramp-up Rate to Preheat 25°C to 150°C	-	-	2	3	K/s
Time t_s T_{Smin} to T_{Smax}	t_s	60	100	120	s
Ramp-up Rate to Peak T_{Smax} to T_p	-	-	2	3	K/s
Liquidus Temperature	T_L	217			°C
Time above Liquidus temperature	t_L	-	80	100	s
Peak Temperature	T_P	-	245	255	°C
Time within 5°C of the specified peak temperature T_p-5 K	t_p	10	20	30	s
Ramp-down Rate T_p to 100°C	-	-	3	6	K/s
Time 25°C to T_p	-	-	-	480	-

Note:

All temperatures refer to topside of the package, measured on the package body surface.

Dimensions For Cannulation And Packaging

Quantity:1000PCS

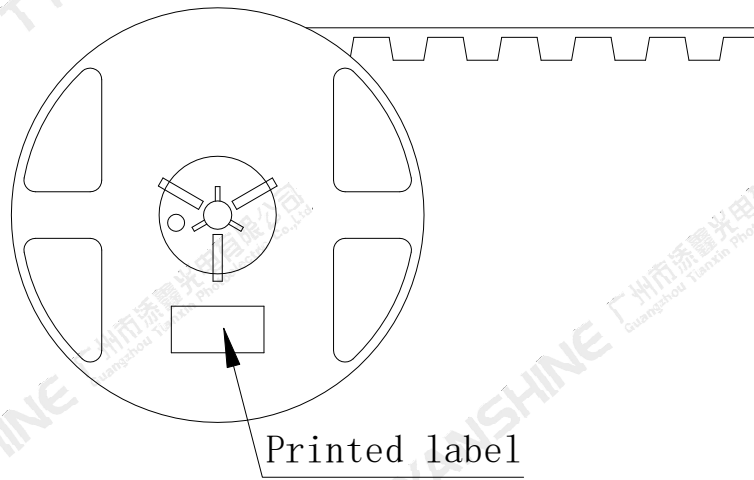
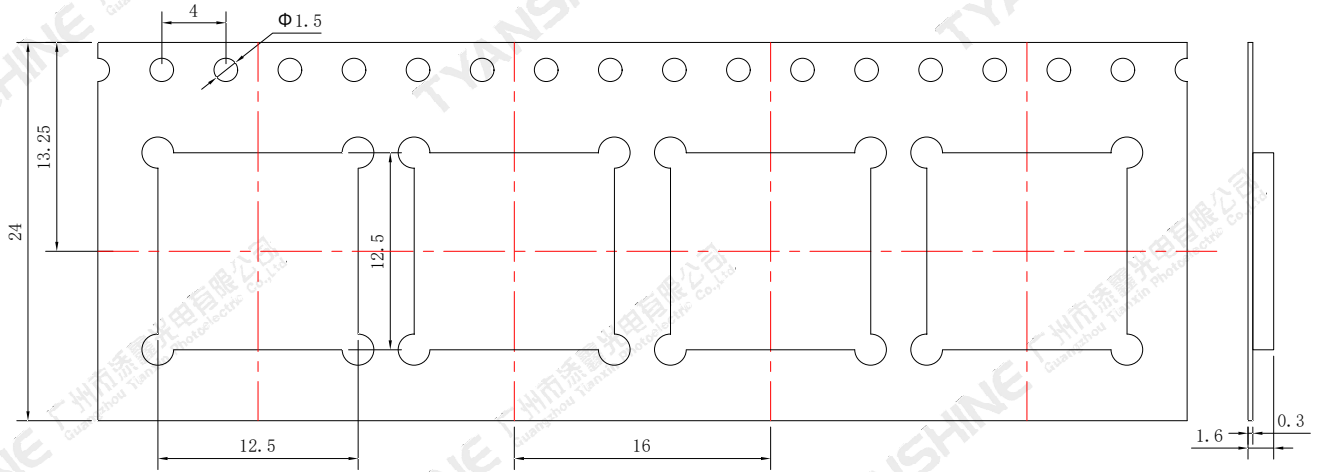

Notes:

1. All dimensions are in millimeters.
2. Tolerances are ± 2.0 mm unless otherwise noted.
3. The products are packaged together with silica gel, Transport, not to the weight of welding LED light-emitting area, As a result of the weight of LED light-emitting zone in the quality of, Irresponsible of the Company.

Part No.	TX-1212RGBW200FC120-NUVENG-01A	Spec No.	PE-B20260601-1	Page	9 of 10
----------	--------------------------------	----------	----------------	------	---------

